

Anhang 1

Strukturdaten 2000 - 2010

Kanton	Bezirk	Gemeinde	EinwohnerInnen				Arbeits- plätze 2008
			2000	2010	Diff. 00-10		
Solothurn	Dorneck	Büren	856	953	+97	+11%	131
	Dorneck	Dornach	5'821	6'299	+478	+8%	2'183
	Dorneck	Gempen	698	819	+121	+17%	287
	Dorneck	Hochwald	1'127	1'244	+117	+10%	134
	Dorneck	Nuglar-St. Pantalon	1'335	1'470	+135	+10%	116
	Dorneck	Seewen	986	1'008	+22	+2%	120
	Thierstein	Himmelried	960	933	-27	-3%	59
	Therstein	Nunningen	1'843	1'843	0		630
Basel-Landschaft	Laufen	Duggingen	1'182	1'487	+305	+26%	523
	Laufen	Grellingen	1'636	1'750	+114	+7%	460
	Liestal	Bubendorf	4'307	4'372	+65	+2%	2'261
	Liestal	Lupsingen	1'262	1'355	+93	+7%	91
	Liestal	Ramlinsburg	640	690	+50	+8%	82
	Liestal	Seltisberg	1'228	1'287	+59	+5%	171
	Liestal	Ziefen	1'411	1'575	+164	+12%	386
	Waldenburg	Arboldswil	502	515	+13	+3%	61
	Waldenburg	Bennwil	618	638	+20	+3%	116
	Waldenburg	Bretzwil	727	790	+63	+9%	59
	Waldenburg	Hölstein	2'110	2'329	+219	+10%	726
	Waldenburg	Lampenberg	475	517	+42	+9%	27
	Waldenburg	Lauwil	324	334	+10	+3%	60
	Waldenburg	Liedertswil	145	160	+15	+10%	67
	Waldenburg	Niederdorf	1'787	1'792	+5	+0%	676
	Waldenburg	Oberdorf	2'331	2'284	-47	-2%	1'158
	Waldenburg	Reigoldswil	1'506	1'556	+50	+3%	424
Waldenburg	Titterten	408	416	+8	+2%	50	
Waldenburg	Waldenburg	1'345	1'221	-124	-9%	605	
	Total		37'570	39'637	+2'067	+6%	11'663

Quellen:

<http://www.pendlerstatistik.admin.ch>

Bundesamt für Statistik bfs

Statistisches Amt Kanton Basel-Landschaft

Statistikdienst Kanton Solothurn

Metron 06.03.2012

F:\daten\M7\11-107-00\5_DIVERS\strukturdaten\lew_pendler_111109.xlsx\Daten VZ

Anhang 2

Erwerbstätige und BerufspendlerInnen 2000

Kanton	Gemeinde	Erwerbs- tätige	Wegpendler		Pendler		Saldo ZP-WP	
			abs.	in %	Binnen- pendler	Zupendler abs. in %		
Solothurn	Büren	447	348	78%	99	57	44%	-291
	Dornach	2'946	2'045	69%	901	1'140	52%	-905
	Gempen	392	246	63%	146	228	79%	-18
	Hochwald	566	435	77%	131	47	35%	-388
	Nuglar-St. Pantalon	706	588	83%	118	39	34%	-549
	Seewen	501	355	71%	146	65	54%	-290
	Himmelried	534	451	84%	83	15	25%	-436
	Nunningen	958	611	64%	347	300	48%	-311
Basel-Landschaft	Duggingen	580	475	82%	105	268	51%	-207
	Grellingen	841	656	78%	185	272	59%	-384
	Bubendorf	2150	1'590	74%	560	1'158	51%	-432
	Lupsingen	657	560	85%	97	31	34%	-529
	Ramlinsburg	358	290	81%	68	14	17%	-276
	Seltisberg	583	474	81%	109	87	51%	-387
	Ziefen	663	463	70%	200	217	56%	-246
	Arboldswil	261	204	78%	57	29	48%	-175
	Bennwil	331	243	73%	88	75	65%	-168
	Bretzwil	366	249	68%	117	66	112%	-183
	Hölstein	1'080	810	75%	270	449	62%	-361
	Lampenberg	221	170	77%	51	10	37%	-160
	Lauwil	148	104	70%	44	23	38%	-81
	Liedertswil	105	73	70%	32	43	64%	-30
	Niederdorf	995	677	68%	318	440	65%	-237
	Oberdorf	1'197	797	67%	400	660	57%	-137
	Reigoldswil	730	486	67%	244	220	52%	-266
	Titterten	200	136	68%	64	37	74%	-99
Waldenburg	675	459	68%	216	458	76%	-1	
	Total	19'191	13'995	73%	5'196	6'448	55%	-7'547

Quellen:

<http://www.pendlerstatistik.admin.ch>

Bundesamt für Statistik bfs

Statistisches Amt Kanton Basel-Landschaft

Statistikdienst Kanton Solothurn

Metron 20.01.2012

F:\daten\M7\11-107-00\5_DIVERS\strukturdaten\lew_pendler_111109.xlsx\Daten VZ

Anhang 3

Wichtigste Arbeitsorte der Wegpendler 2000

Gemeinde	Wegpendler			Wegpendler nach																			Subtotal 1-5
	Total	Anteil ÖV		1. Arbeitsort				2. Arbeitsort				3. Arbeitsort			4. Arbeitsort			5. Arbeitsort					
		abs.	in %	abs.	in %	abs.	in %	abs.	in %	abs.	in %	abs.	in %	abs.	in %	abs.	in %	abs.	in %				
Büren	348	112	32%	Basel	97	28%	47	48%	Liestal	91	26%	36	40%	Pratteln	19	5%	Muttenz	13	3%	Sissach	12	3%	67%
Dornach	2'045	751	37%	Basel	843	41%	451	53%	Arllesheim	212	10%	31	15%	Reinach BL	155	8%	Aesch BL	125	6%	Münchenstein	111	5%	71%
Gempen	246	53	22%	Basel	66	27%	27	41%	Arllesheim	21	9%	2	10%	Reinach BL	19	8%	Dornach	17	7%	Muttenz	16	7%	57%
Hochwald	435	84	19%	Basel	171	39%	48	28%	Dornach	41	9%	9	22%	Reinach BL	36	8%	Arllesheim	26	6%	Muttenz	18	4%	67%
Nuglar-St. Pantalon	588	148	25%	Liestal	152	26%	36	24%	Basel	128	22%	59	46%	Muttenz	43	7%	Pratteln	27	5%	Reinach BL	16	3%	62%
Seewen	355	71	20%	Basel	97	27%	37	38%	Reinach BL	26	7%	3	12%	Liestal	23	6%	Münchenstein	19	5%	Muttenz	17	5%	51%
Himmelried	451	105	23%	Basel	165	37%	63	38%	Reinach BL	36	8%	2	6%	Breitenbach	24	5%	Nunningen	20	4%	Laufen	18	4%	58%
Nunningen	611	155	25%	Basel	139	23%	59	42%	Breitenbach	83	14%	26	31%	Laufen	63	10%	Liestal	24	4%	Dornach	18	3%	54%
Duggingen	475	132	28%	Basel	192	40%	88	46%	Aesch BL	45	9%	3	7%	Reinach BL	28	6%	Arllesheim	25	5%	Münchenstein	22	5%	66%
Grellingen	656	209	32%	Basel	231	35%	97	42%	Aesch BL	67	10%	14	21%	Laufen	43	7%	Reinach BL	41	6%	Münchenstein	33	5%	63%
Bubendorf	1'590	590	37%	Liestal	438	28%	161	37%	Basel	376	24%	215	57%	Pratteln	85	5%	Muttenz	81	5%	Lausen	42	3%	64%
Lupsingen	560	182	33%	Liestal	159	28%	45	28%	Basel	150	27%	73	49%	Pratteln	29	5%	Muttenz	27	5%	Bubendorf	21	4%	69%
Ramlinsburg	290	57	20%	Liestal	71	24%	13	18%	Basel	62	21%	19	31%	Muttenz	22	8%	Bubendorf	21	7%	Pratteln	12	4%	65%
Seltisberg	474	160	34%	Liestal	173	36%	57	33%	Basel	117	25%	61	52%	Pratteln	29	6%	Bubendorf	17	4%	Sissach	13	3%	74%
Ziefen	463	176	38%	Liestal	116	25%	55	47%	Basel	82	18%	43	52%	Bubendorf	27	6%	Muttenz	26	6%	Reigoldswil	23	5%	59%
Arboldswil	204	69	34%	Liestal	49	24%	22	45%	Basel	31	15%	21	68%	Bubendorf	21	10%	Hölstein	13	6%	Pratteln	12	6%	62%
Bennwil	243	44	18%	Liestal	36	15%	13	36%	Basel	34	14%	12	35%	Oberdorf BL	17	7%	Hölstein	16	7%	Niederdorf	13	5%	48%
Bretzwil	249	43	17%	Basel	49	20%	14	29%	Liestal	33	13%	6	18%	Bubendorf	18	7%	Nunningen	14	6%	Reigoldswil	11	4%	50%
Hölstein	810	296	37%	Liestal	179	22%	78	44%	Basel	152	19%	91	60%	Niederdorf	53	7%	Pratteln	42	5%	Muttenz	37	5%	57%
Lampenberg	170	48	28%	Liestal	43	25%	16	37%	Basel	35	21%	18	51%	Hölstein	14	8%	Muttenz	10	6%	Bubendorf	7	4%	64%
Lauwil	104	34	33%	Liestal	19	18%	8	42%	Basel	19	18%	7	37%	Reigoldswil	7	7%	Oberdorf BL	7	7%	Ziefen	6	6%	56%
Liedertswil	73	9	12%	Basel	13	18%	3	23%	Liestal	9	12%	0	0%	Niederdorf	7	10%	Pratteln	5	7%	Bubendorf	5	7%	53%
Niederdorf	677	231	34%	Liestal	114	17%	52	46%	Basel	98	14%	54	55%	Oberdorf BL	89	13%	Waldenburrig	51	8%	Hölstein	49	7%	59%
Oberdorf	797	208	26%	Liestal	162	20%	82	51%	Basel	112	14%	65	58%	Waldenburg	71	9%	Niederdorf	69	9%	Bubendorf	33	4%	56%
Reigoldswil	486	165	34%	Liestal	100	21%	47	47%	Basel	85	17%	47	55%	Bubendorf	44	9%	Tenniken	18	4%	Oberdorf BL	16	3%	54%
Titterten	136	34	25%	Liestal	33	24%	12	36%	Basel	18	13%	4	22%	Reigoldswil	11	8%	Niederdorf	10	7%	Bubendorf	7	5%	58%
Waldenburg	459	156	34%	Liestal	84	18%	28	33%	Basel	58	13%	36	62%	Oberdorf BL	56	12%	Niederdorf	25	5%	Hölstein	24	5%	54%
Total	13'995	4'322	31%	Total	3'991	29%	1'659		Total	2'221	16%	957		Total	1'053	8%		789	6%		612	4%	58%

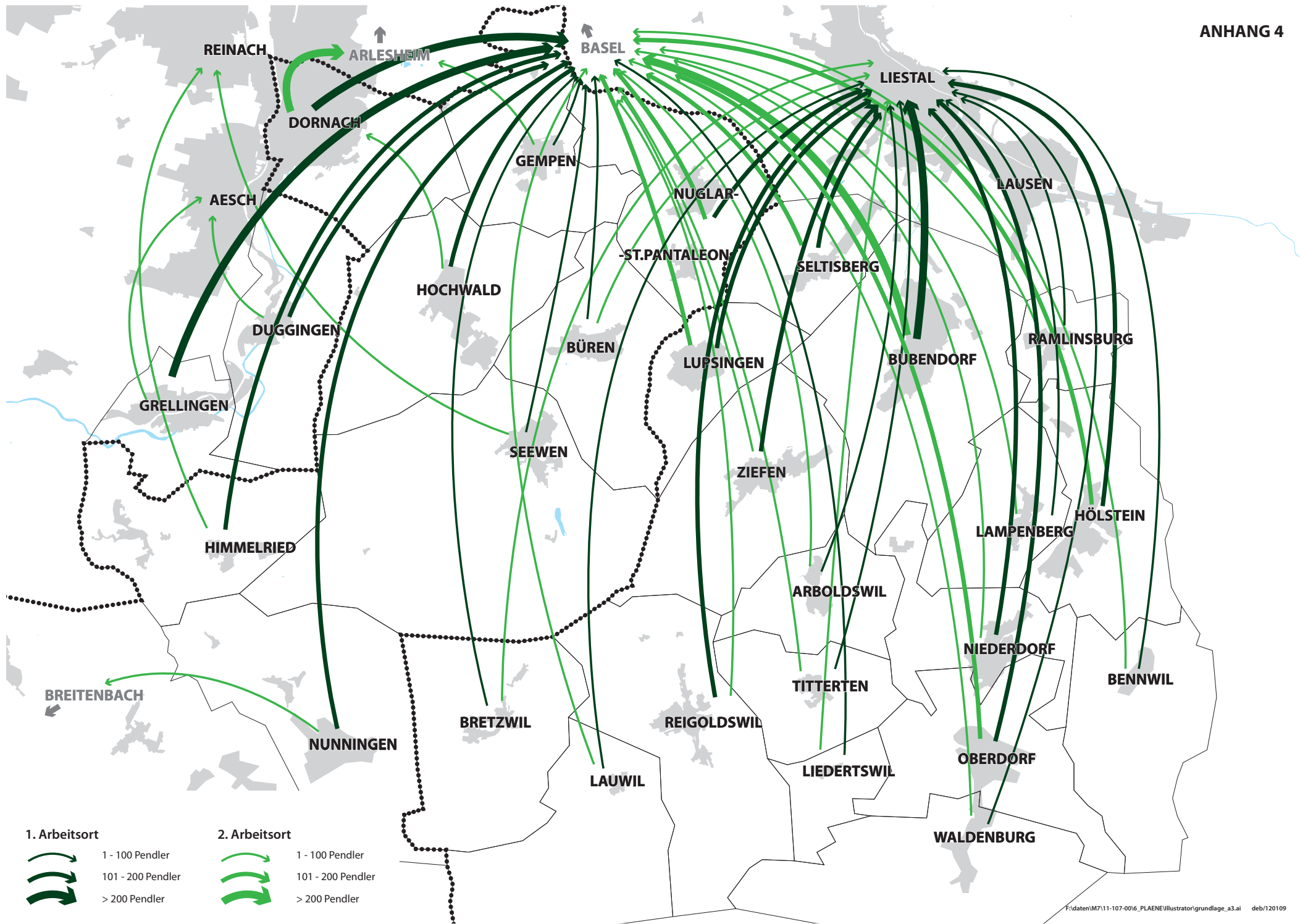

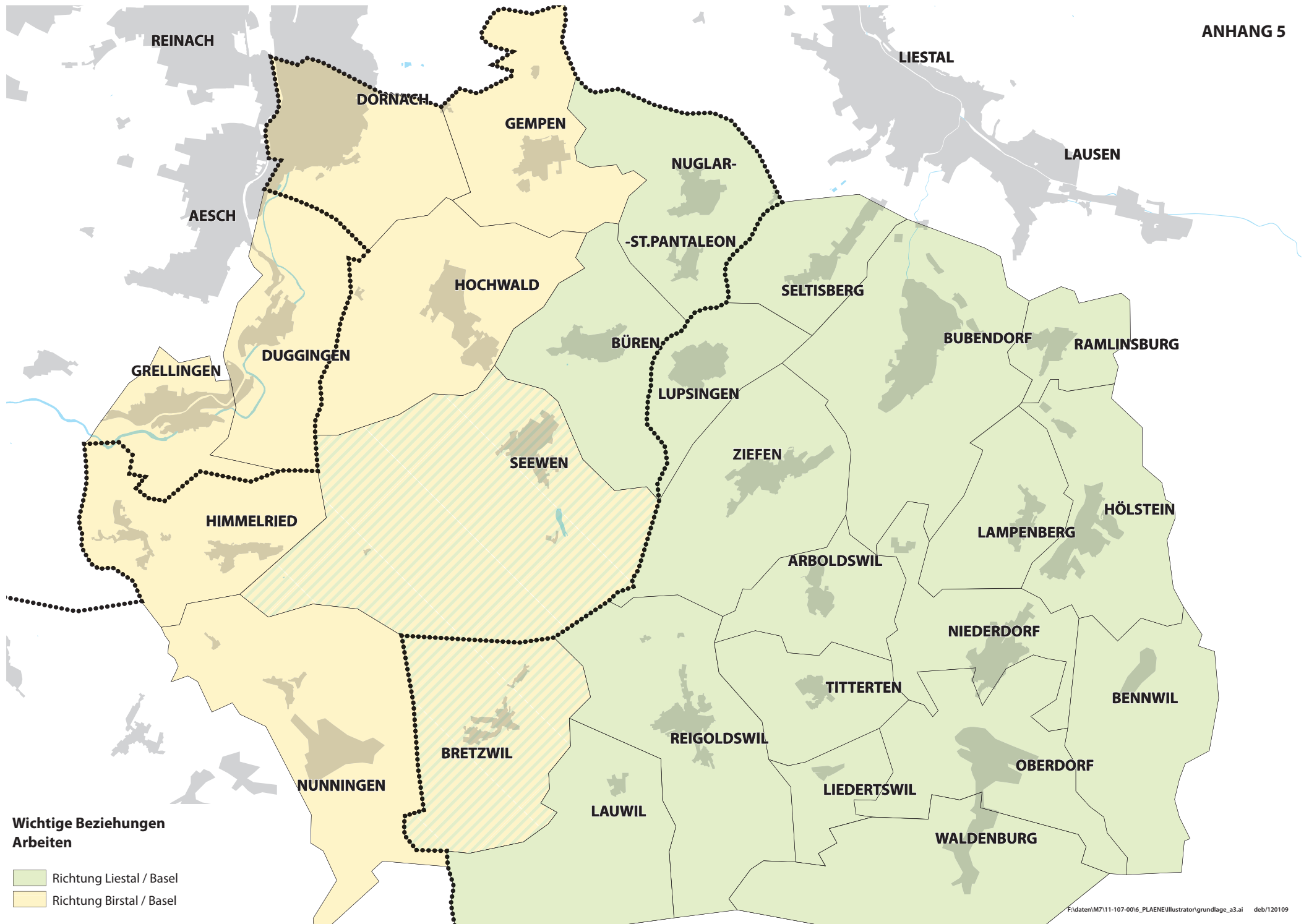

**Wichtige Beziehungen
Arbeiten**

- Richtung Liestal / Basel
- Richtung Birstal / Basel

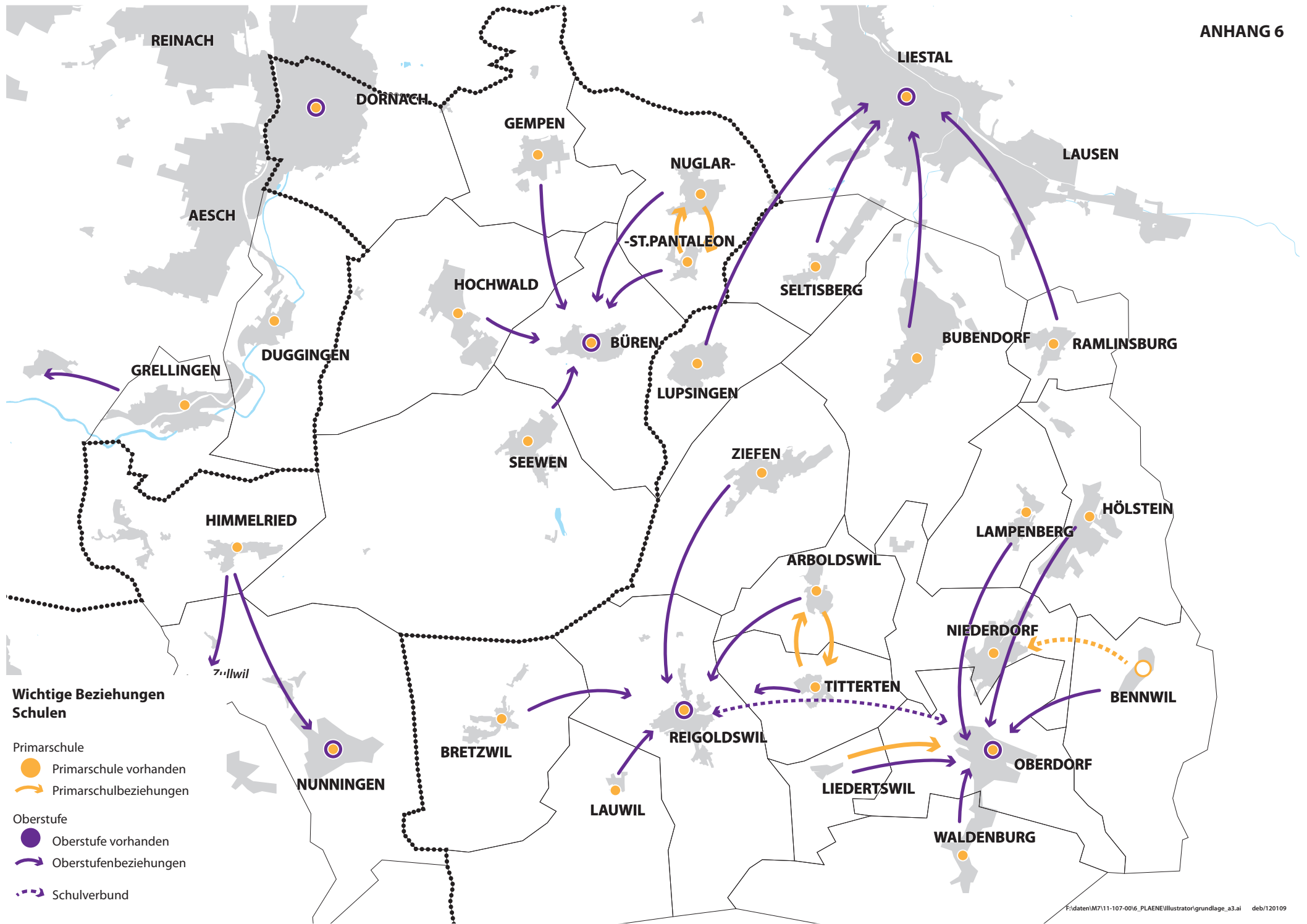

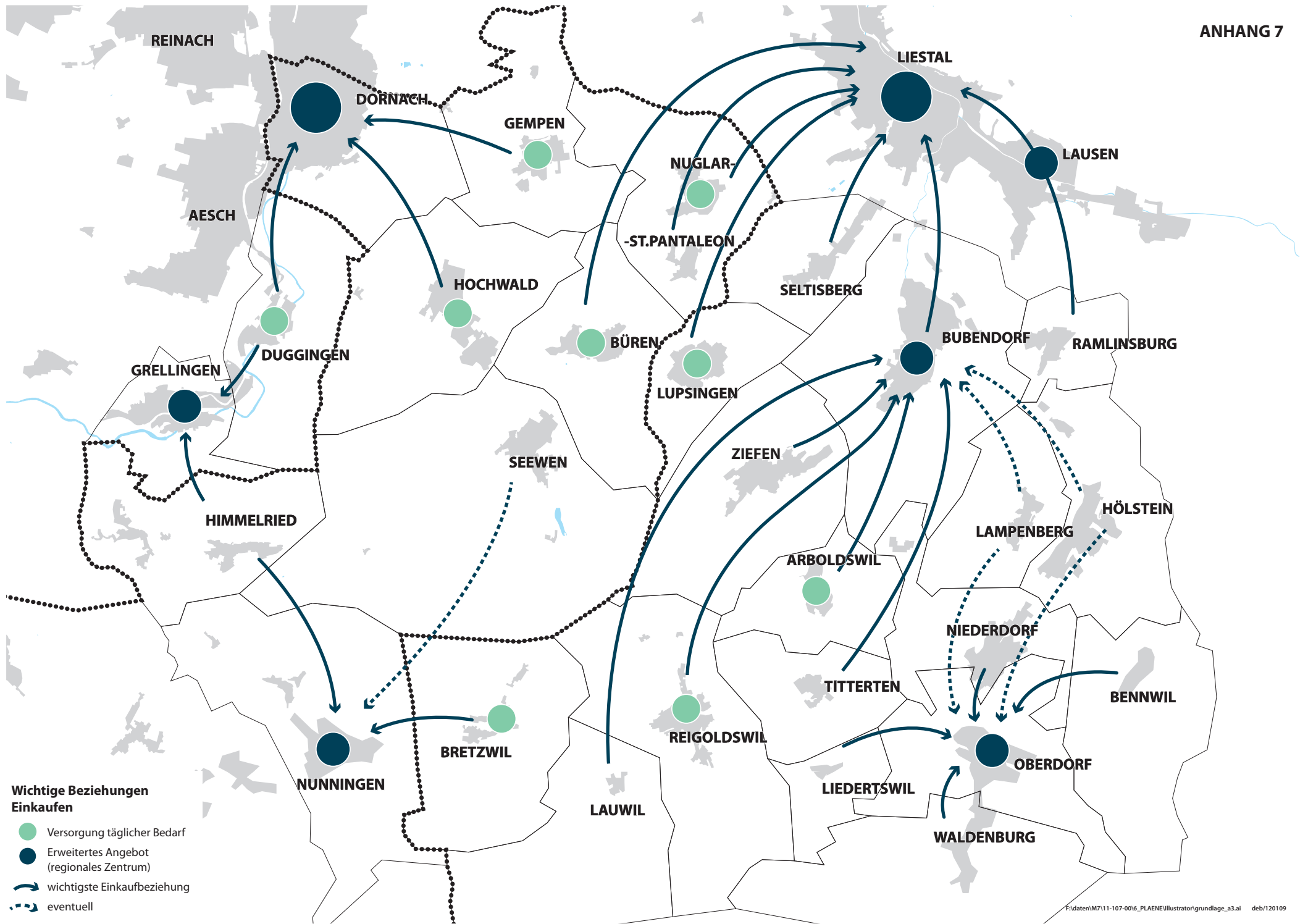

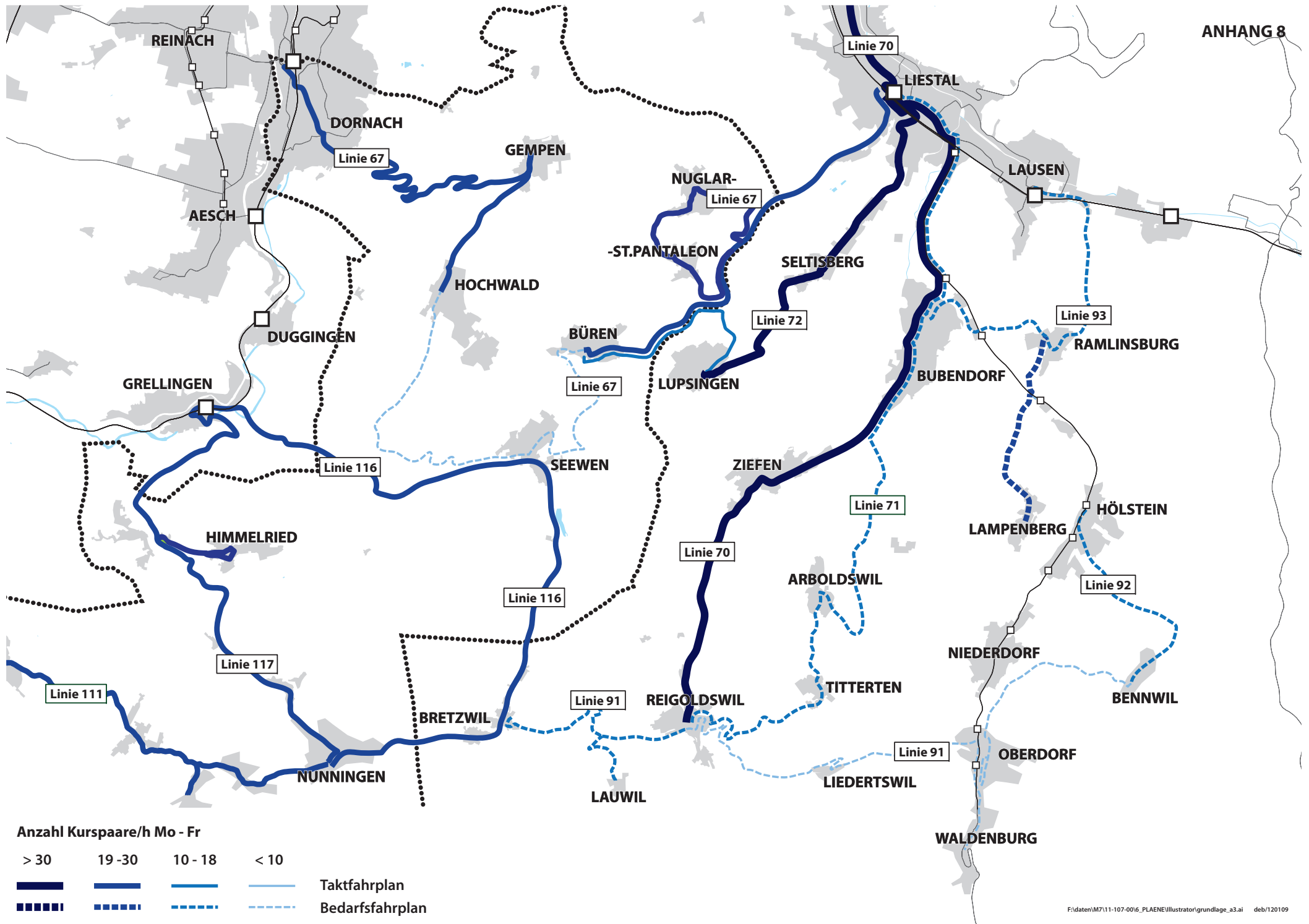

Anhang 9: Konzeptvarianten Dorneckberg

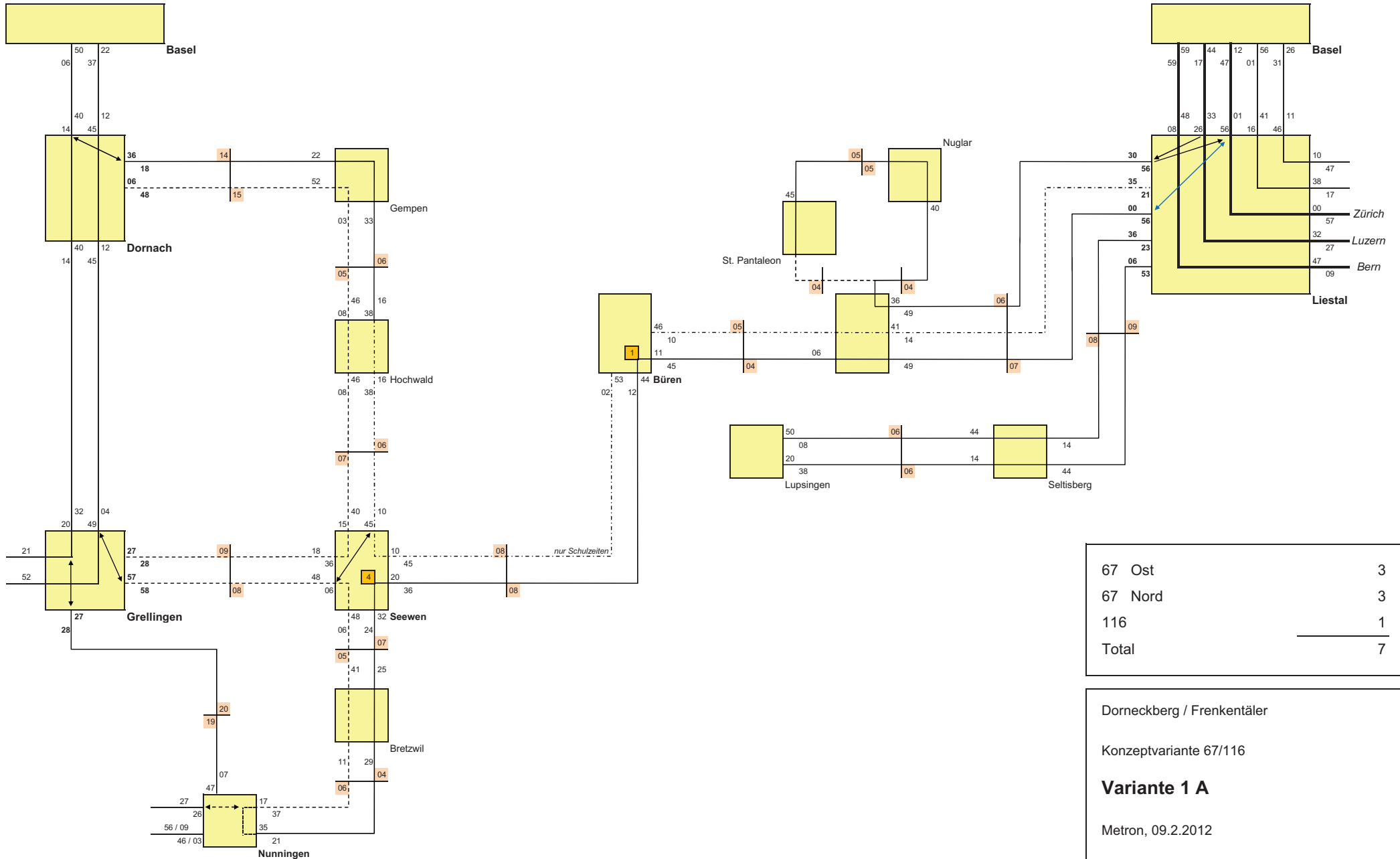

67 Ost	3
67 Nord	3
116	1
Total	7

Dorneckberg / Frenkentäler
 Konzeptvariante 67/116
Variante 1 A
 Metron, 09.2.2012

Anhang 9: Konzeptvarianten Dorneckberg

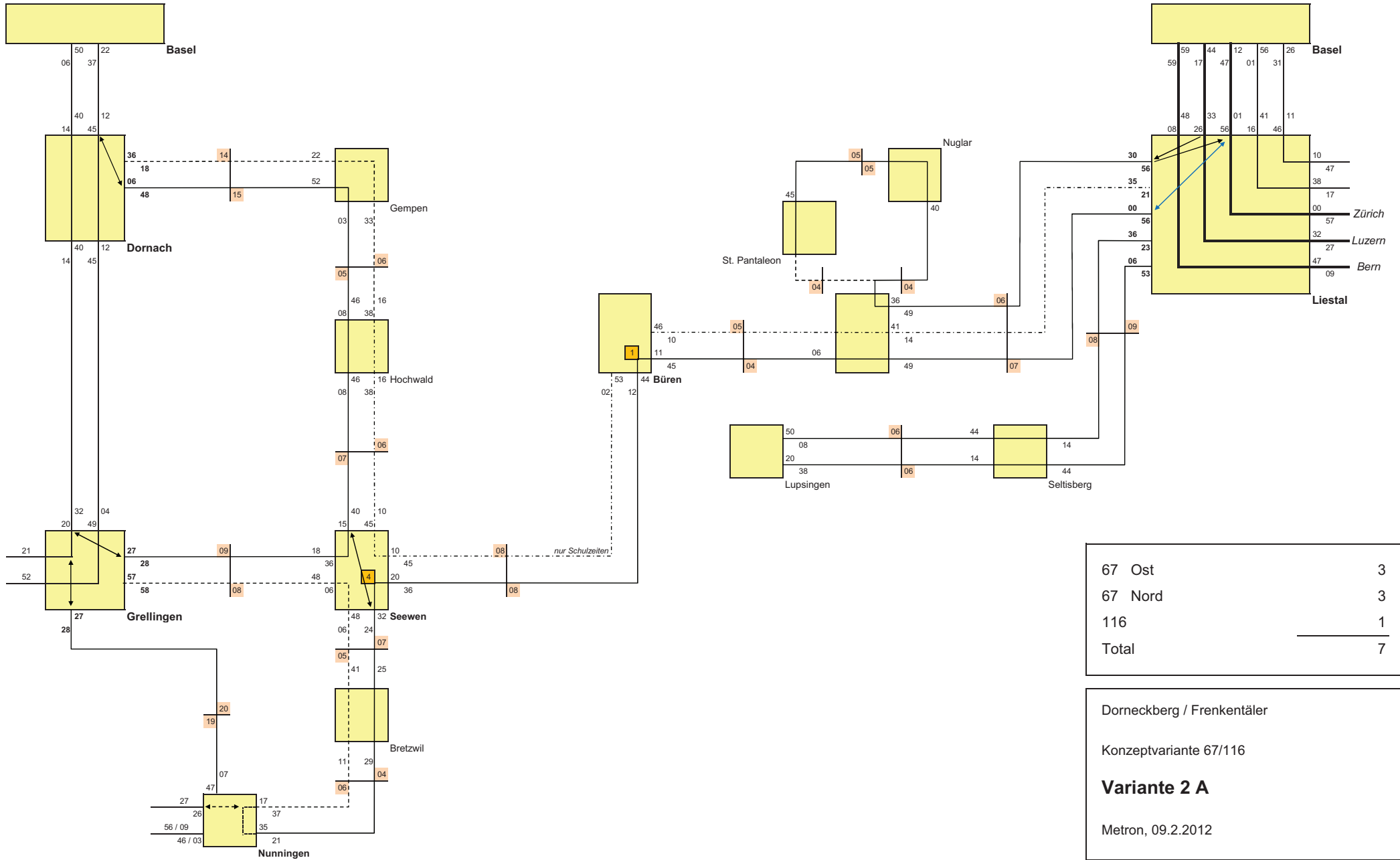

67 Ost	3
67 Nord	3
116	1
Total	7

Dorneckberg / Frenkentäler
 Konzeptvariante 67/116
Variante 2 A
 Metron, 09.2.2012

Anhang 9: Konzeptvarianten Dorneckberg

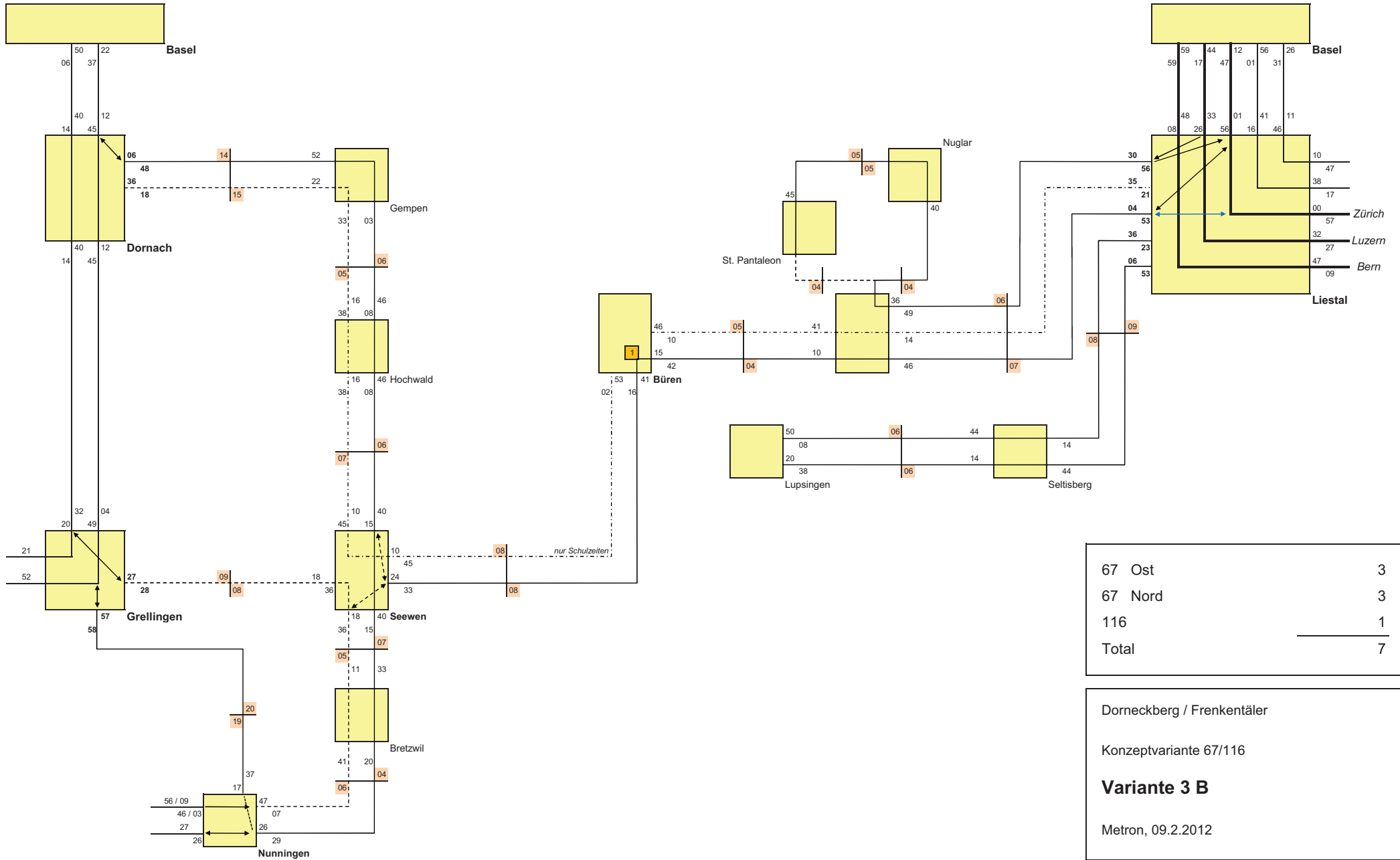

Anhang 9: Konzeptvarianten Dorneckberg

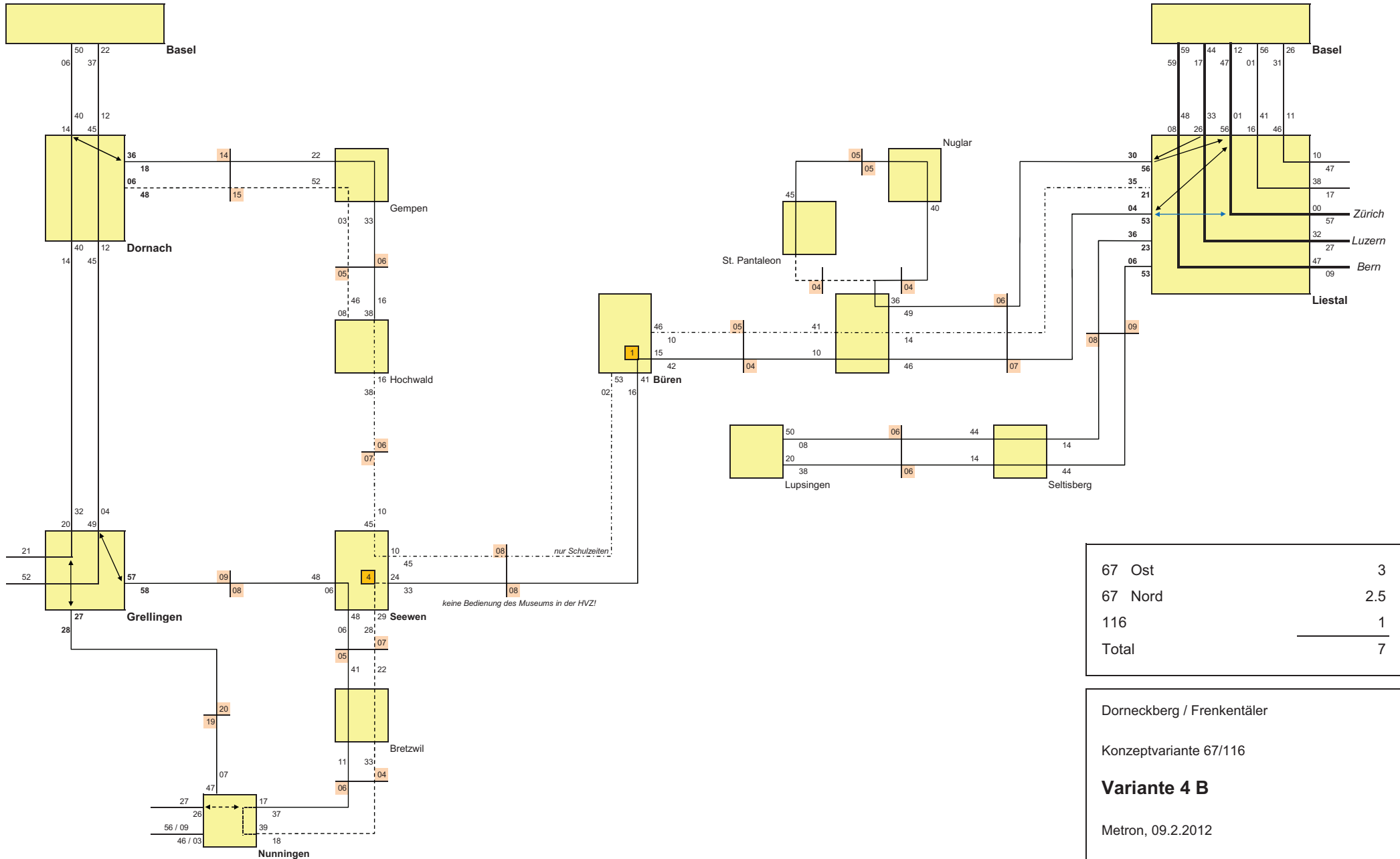

Anhang 9: Konzeptvarianten Dorneckberg

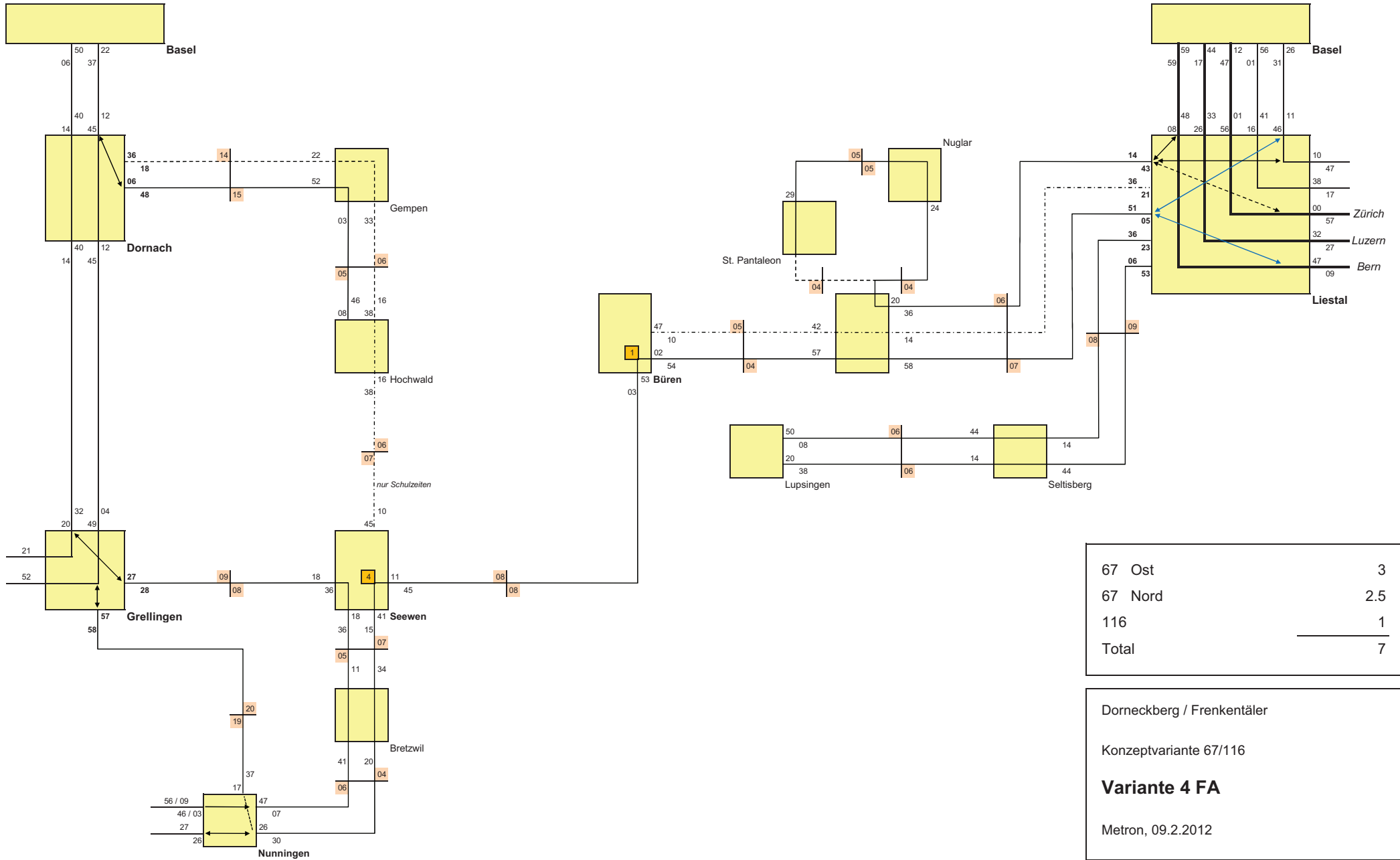

**Anhang 10:
Konzeptvorschlag**

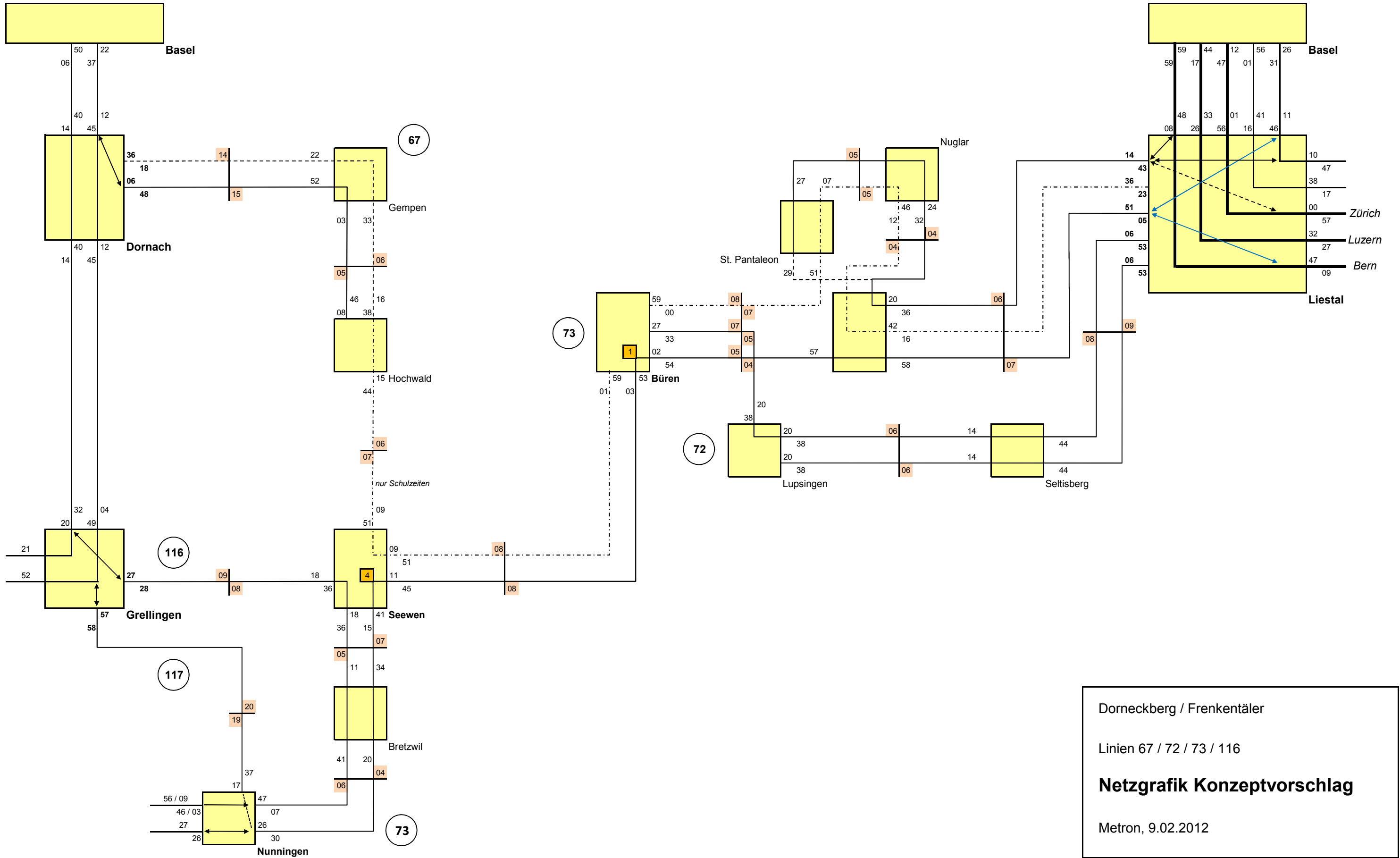

Dorneckberg / Frenkentaler
 Linien 67 / 72 / 73 / 116
Netzgrafik Konzeptvorschlag
 Metron, 9.02.2012

Anhang 11: Fahrplanentwürfe

Linie 67 Dornach-Arlesheim - Hochwald (- Seewen - Büren)

Stand: 9.2.2012

Montag - Freitag

		1	2					2				2				2			3			2			3			1			2				
→																																			
<i>S3 von Basel</i>	an			05.45	06.14	06.45	07.14	07.45		08.45	09.45	10.45		11.45	12.14	13.45	13.14	13.45	14.45		15.45				16.45	17.14		14.45	18.14	18.40	19.14	20.14	21.14	22.14	23.14
Dornach-Arlesheim	ab			05.48	06.18	06.48	07.18	07.48		08.48	09.48	10.48		11.48	12.18	12.48	13.18	13.48	14.48		15.48				16.48	17.18		17.48	18.18	18.48	19.18	20.18	21.18	22.18	23.18
Gempen	ab			06.03	06.33	07.03	07.33	08.03	08.28	09.03	10.03	11.03		12.03	12.33	13.03	13.33	14.03	15.03		16.03				17.03	17.33		18.03	18.33	19.03	19.33	20.33	21.33	22.33	23.33
Hochwald	an			06.08	06.38	07.08	07.38	08.08	08.33	09.08	10.08	11.08		12.08	12.38	13.08	13.38	14.08	15.08		16.08				17.08	17.38		18.08	18.38	19.08	19.38	20.38	21.38	22.38	23.38
Hochwald	ab						07.44		08.34											L		L		L								20.38	21.38	22.38	23.38
Seewen	ab						07.51		08.41																							20.45	21.45	22.45	23.45
Büren	an						07.59		08.49																										

←																																					
Büren	ab						L		L												15.11		16.11		17.01		18.01										
Seewen	ab																				15.19		16.19		17.09		18.09							20.47	21.47	22.47	23.47
Hochwald	an																				15.25		16.25		17.15		18.15							20.53	21.53	22.53	23.53
Hochwald	ab	05.16	05.46	06.16	06.46	07.16		08.16		09.16	10.16	11.16	11.46	12.16	12.46	13.16		14.16	15.16	15.26	16.16	16.26	16.46		17.16	17.46		18.16	18.46		19.46	20.53	21.53	22.53			
Gempen	an	05.22	05.52	06.22	06.52	07.22		08.22		09.22	10.22	11.22	11.52	12.22	12.52	13.22		14.22	15.22	15.32	16.22	16.32	16.52		17.22	17.52		18.22	18.52		19.52						
Dornach-Arlesheim	an	05.36	06.06	06.36	07.06	07.36		08.36		09.36	10.36	11.36	12.06	12.36	13.06	13.36		14.36	15.36	16.36	16.36	16.36	17.06		17.36	18.06		18.36	19.06		20.06	21.09	22.09	23.09			
<i>S3 nach Basel</i>	ab	05.40	06.12	06.40	07.12	07.40		08.40		09.40	10.40	11.40	12.12	12.40	13.12	13.40		14.40	15.40	16.40	16.40	17.12		17.40	18.12		18.40	19.12		20.12	21.12	22.12	23.12				

Schulkurse
 Schulbeginn Büren
 Schulschluss Büren

08.10 09.00

15.00 16.00 16.50

Anhang 11: Fahrplanentwürfe

Linie 67 Dornach-Arlesheim - Hochwald

Stand: 9.2.2012

Samstag



<i>S3 von Basel</i>	<i>an</i>																					
Dornach-Arlesheim	ab			06.08	06.56	07.48	08.48	09.48	10.48	11.48	12.48	13.48	14.48	15.48	16.48	17.48	18.48					
Gempen	ab			06.23	07.11	08.03	09.03	10.03	11.03	12.03	13.03	14.03	15.03	16.03	17.03	18.03	19.03					
Hochwald	an			06.28	07.16	08.08	09.08	10.08	11.08	12.08	13.08	14.08	15.08	16.08	17.08	18.08	19.08					
Hochwald	ab																					
Seewen	ab																					
Büren	an																					



Büren	ab																						
Seewen	ab																						
Hochwald	an																						
Hochwald	ab			05.46	06.36	07.16	08.16	09.16	10.16	11.16	12.16	13.16	14.16	15.16	16.16	17.16	18.16	19.16	19.46				
Gempen	ab			05.52	06.42	07.22	08.22	09.22	10.22	11.22	12.22	13.22	14.22	15.22	16.22	17.22	18.22	19.22	19.52				
Dornach-Arlesheim	an			06.06	06.56	07.36	08.36	09.36	10.36	11.36	12.36	13.36	14.36	15.36	16.36	17.36	18.36	19.36	20.06				
<i>S3 nach Basel</i>	<i>ab</i>			06.12	07.12	07.40	08.40	09.40	10.40	11.40	12.40	13.40	14.40	15.40	16.40	17.40	18.40	19.40	20.12				

Anhang 11: Fahrplanentwürfe

Linie 67 Dornach-Arlesheim - Hochwald

Stand: 9.2.2012

Sonntag

⇒

<i>S3 von Basel</i>	<i>an</i>																								
Dornach-Arlesheim	ab																								
Gempen	ab																								
Hochwald	an																								
Hochwald	ab																								
Seewen	ab																								
Büren	an																								

⇐

Büren	ab																								
Seewen	ab																								
Hochwald	an																								
Hochwald	ab																								
Gempen	an																								
Dornach-Arlesheim	an																								
S3 nach Basel	ab																								

Zusätzliche Kurse

Anhang 12: Fahrplanentwürfe

Linie 71 Liestal - Titterten - Reigoldswil

Stand: 9.2.2012

Montag - Freitag

		1	2	2	2	2	2	2	2	2	2	2	2	2	2	2	1		
→																			
S3 von Basel	an		05.46	06.46	07.46	08.16									15.46	16.46	17.46	18.46	
IR von Basel	an						08.56	09.56	10.56	11.56	12.56	13.56	14.56					19.56	
Liestal	ab	05.51	06.51	07.51	08.21		09.05	10.05	11.05	12.05	13.05	14.05	15.05		15.51	16.51	17.51	18.51	20.05
Bubendorf Unterdorf	an	05.59	06.59	07.59	08.29		09.13	10.13	11.13	12.13	13.13	14.13	15.13		15.59	16.59	17.59	18.59	20.13
Bubendorf Unterdorf	ab	05.59	06.59	07.59	08.29		09.14	10.14	11.14	12.14	13.14	14.14	15.14		15.59	16.59	17.59	18.59	20.14
Reigoldswil	an	06.20	07.20	08.20	08.50		09.35	10.35	11.35	12.35	13.35	14.35	15.35		16.20	17.20	18.20	19.20	20.35

		1	2	2	2	2	2	2	2	2	2	2	2	2	2	2	1		
←																			
Reigoldswil	ab	05.34	06.34	07.34	08.34		08.53	09.53	10.53	11.53	12.53	13.53	14.53		15.34	16.34	17.34	18.34	19.53
Bubendorf Unterdorf	an	05.54	06.54	07.54	08.54		09.13	10.13	11.13	12.13	13.13	14.13	15.13		15.54	16.54	17.54	18.54	20.13
Bubendorf Unterdorf	ab	05.54	06.54	07.54	08.54		09.14	10.14	11.14	12.14	13.14	14.14	15.14		15.54	16.54	17.54	18.54	20.14
Liestal	an	06.04	07.04	08.04	09.04		09.24	10.24	11.24	12.24	13.24	14.24	15.24		16.04	17.04	18.04	19.04	20.24
IR nach Basel	ab						09.33	10.33	11.33	12.33	13.33	14.33	15.33						20.33
S3 nach Basel	ab	06.11	07.11	08.11	09.11										16.11	17.11	18.11	19.11	

Kurs der Linie 70

Schulbeginn Reigoldswil	7.30	8.20					11.50	13.45						15.20	16.15	17.00
Schulschluss Reigoldswil																

Bemerkung:
 Standzeiten HVZ Morgen (6.04 - 6.51 und 7.04 - 7.51) für Verdichtungskurse auf der Linie 72 verwendbar
 Standzeiten HVZ Nachmittag (16.04 - 16.51 und 17.04 - 17.51) für Verdichtungskurse auf der Linie 72 verwendbar

Anhang 12: Fahrplanentwürfe

Linie 71 Liestal - Titterten - Reigoldswil

Stand: 9.2.2012

Samstag



<i>S3 von Basel</i>	<i>an</i>																		
<i>IR von Basel</i>	<i>an</i>			06.56	07.56	08.56		10.56	11.56	12.56	13.56			16.56	17.56	18.56	19.56		
Liestal	<i>ab</i>			07.05	08.05	09.05		11.05	12.05	13.05	14.05			17.05	18.05	19.05	20.05		
Bubendorf Unterdorf	<i>an</i>			07.13	08.13	09.13		11.13	12.13	13.13	14.13			17.13	18.13	19.13	20.13		
Bubendorf Unterdorf	<i>ab</i>			07.14	08.14	09.14		11.14	12.14	13.14	14.14			17.14	18.14	19.14	20.14		
Reigoldswil	<i>an</i>			07.35	08.35	09.35		11.35	12.35	13.35	14.35			17.35	18.35	19.35	20.35		



Reigoldswil	<i>ab</i>		06.53	07.53	08.53		10.53	11.53	12.53	13.53				16.53	17.53	18.53	19.53		
Bubendorf Unterdorf	<i>an</i>		07.13	08.13	09.13		11.13	12.13	13.13	14.13				17.13	18.13	19.13	20.13		
Bubendorf Unterdorf	<i>ab</i>			07.14	08.14	09.14		11.14	12.14	13.14	14.14			17.14	18.14	19.14	20.14		
Liestal	<i>an</i>			07.24	08.24	09.24		11.24	12.24	13.24	14.24			17.24	18.24	19.24	20.24		
<i>IR nach Basel</i>	<i>ab</i>			07.33	08.33	09.33		11.33	12.33	13.33	14.33			17.33	18.33	19.33	20.33		
<i>S3 nach Basel</i>	<i>ab</i>																		

Kurs der Linie 70

Anhang 12: Fahrplanentwürfe

Linie 71 Liestal - Titterten - Reigoldswil

Stand: 9.2.2012

Sonntag



<i>S3 von Basel</i>	<i>an</i>																		
<i>IR von Basel</i>	<i>an</i>			07.56	08.56			11.56	12.56				16.56	17.56	18.56				
Liestal	<i>ab</i>			08.05	09.05			12.05	13.05				17.05	18.05	19.05				
Bubendorf Unterdorf	<i>an</i>			08.13	09.13			12.13	13.13				17.13	18.13	19.13				
Bubendorf Unterdorf	<i>ab</i>			08.14	09.14			12.14	13.14				17.14	18.14	19.14				
Reigoldswil	<i>an</i>			08.35	09.35			12.35	13.35				17.35	18.35	19.35				



Reigoldswil	<i>ab</i>			07.53	08.53			11.53	12.53				16.53	17.53	18.53				
Bubendorf Unterdorf	<i>an</i>			08.13	09.13			12.13	13.13				17.13	18.13	19.13				
Bubendorf Unterdorf	<i>ab</i>			08.14	09.14			12.14	13.14				17.14	18.14	19.14				
Liestal	<i>an</i>			08.24	09.24			12.24	13.24				17.24	18.24	19.24				
<i>IR nach Basel</i>	<i>ab</i>			08.33	09.33			12.33	13.33				17.33	18.33	19.33				
<i>S3 nach Basel</i>	<i>ab</i>																		

Kurs der Linie 70

Anhang 13: Fahrplanentwürfe

Linien 73/74 Liestal - Büren - Seewen - Nunningen

Stand: 9.2.2012

Montag - Freitag

→		2	1	3							3													
IR von Basel	an					06.08	06.26		07.08	07.26		08.08		09.08		10.08		11.08		12.08		13.08		
S3 von Basel	an				05.46		06.46			07.46			08.46		09.46		10.46		11.46		12.46	13.46		
Liestal	ab				05.51	06.14	06.36	06.51	07.14	07.36	07.51	08.14	08.26	08.51	09.14	09.51	10.14	10.51	11.14	11.51	12.14	12.51	13.14	13.51
Nuglar						06.24	06.46		07.24	07.46		08.24	08.36		09.24		10.24		11.24		12.24	13.24		
Büren	an				06.02		06.59	07.02		07.59	08.02		08.49	09.02		10.02		11.02		12.02		13.02	14.02	
Büren	ab				06.03			07.03			08.03			09.03		10.03		11.03		12.03		13.03	14.03	
Seewen	an				06.11			07.11			08.11			09.11		10.11		11.11		12.11		13.11	14.11	
Seewen	ab				06.15			07.15			08.15			09.15		10.15		11.15		12.15		13.15	14.15	
Bretzwil					06.20			07.20			08.20			09.20		10.20		11.20		12.20		13.20	14.20	
Nunningen	an				06.26			07.26			08.26			09.26		10.26		11.26		12.26		13.26	14.26	

←																								
Nunningen	ab		05.30			06.30			07.30			08.30		09.30		10.30		11.30		12.30		13.30	14.30	
Seewen	an		05.41			06.41			07.41			08.41		09.41		10.41		11.41		12.41		13.41	14.41	
Seewen	ab		05.45			06.45			07.45			08.45		09.45		10.45		11.45		12.45		13.45	14.45	
Büren	an		05.53			06.53			07.53			08.53		09.53		10.53		11.53		12.53		13.53	14.53	
Büren	ab	05.28	05.54	06.00	06.54	07.00	07.54	08.00	08.54			09.54		10.54		11.54		12.54		13.54		14.54		
Nuglar	an	05.40	06.05	06.12	06.32	07.12	07.32	08.12	08.32		09.32	10.32		11.32	12.32		13.32		14.32					
Liestal	an	05.51	06.05	06.23	06.43	07.05	07.23	07.43	08.05	08.23	08.43	09.05	09.43	10.05	10.43	11.05	11.43	12.05	12.43	13.05	13.43	14.05	14.43	15.05
S3 nach Basel	ab		06.10			07.10			08.10			09.10		10.10		11.10		12.10		13.10		14.10	15.10	
IR nach Basel	ab	06.01		06.33	06.48		07.33	07.48		08.33	08.48		09.48		10.48		11.48		12.48		13.48		14.48	

Schulbeginn Büren 08.10 09.00
 Schulschluss Büren 12.30

→		3												3		2							1
IR von Basel	an	14.08			15.08			16.08			17.08	17.26		18.08	18.26		19.08						
S3 von Basel	an			14.46		15.46		16.46		17.46		18.46		19.46		20.46	21.46	22.46	23.46				
Liestal	ab	14.14		14.51	15.14	15.36	15.51	16.14	16.36	16.51	17.14	17.36	17.51	18.14	18.36	18.51	19.14	19.51		20.51	21.51	22.51	23.51
Nuglar		14.24		15.24	15.46	16.24	16.46	17.24	17.46		18.24	18.46		19.24	20.01	21.01	22.01	23.01	00.01				
Büren	an			15.02	15.59	16.02		17.02	17.59	18.02		18.59	19.02		20.14	21.14	22.14	23.14	00.14				
Büren	ab			15.03		16.03		17.03		18.03		18.59	19.03		20.15		22.14	23.14	00.14				
Seewen	an			15.11		16.11		17.11		18.11		19.11		20.23									
Seewen	ab			15.15		16.15		17.15		18.15		19.15		20.27									
Bretzwil				15.20		16.20		17.20		18.20		19.20		20.32									
Nunningen	an			15.26		16.26		17.26		18.26		19.26		20.38									

←																							
Nunningen	ab			15.30		16.30		17.30		18.30		19.30											
Seewen	an			15.41		16.41		17.41		18.41		19.41											
Seewen	ab			15.45		16.45		17.45		18.45		19.45											
Büren	an			15.53		16.53		17.53		18.53		19.53											
Büren	ab	15.10		15.54	16.10	16.54	17.00	17.54	18.00	18.54					20.20	21.20	22.20	23.20					
Nuglar	an	15.22	15.32	16.22	16.32	17.12	17.32	18.12	18.32		19.32				20.32	21.32	22.32	23.32					
Liestal	an	15.33	15.43	16.05	16.33	16.43	17.05	17.23	17.43	18.05	18.23	18.43	19.05	19.43		20.43	21.43	22.43	23.43				
S3 nach Basel	ab			16.10		17.10		18.10		19.10													
IR nach Basel	ab		15.48		16.48		17.33	17.48		18.33	18.48		19.48		20.48	21.48	22.48	23.48					

Schulkurse
 Schulbeginn Büren
 Schulschluss Büren
 Zusatzkurse

15.00 16.00 16.50

Anhang 13: Fahrplanentwürfe

Linien 73/74 Liestal - Büren - Seewen - Nunningen

Stand: 9.2.2012

Samstag

→

		1	2																						
<i>IR von Basel</i>	<i>an</i>					07.08		08.08		09.08		10.08		11.08		12.08		13.08		14.08		15.08		16.08	
<i>S3 von Basel</i>	<i>an</i>				06.46	07.46	08.46	09.46	10.46	11.46	12.46	13.46	14.46	15.46											
Liestal	ab				06.51	07.14	07.51	08.14	08.51	09.14	09.51	10.14	10.51	11.14	11.51	12.14	12.51	13.14	13.51	14.14	14.51	15.14	15.51	16.14	
Nuglar						07.24	08.24	09.24	10.24	11.24	12.24	13.24	14.24	15.24	16.24										
Büren	<i>an</i>				07.02		08.02		09.02		10.02		11.02		12.02		13.02		14.02		15.02		16.02		
Büren	<i>ab</i>				07.03		08.03		09.03		10.03		11.03		12.03		13.03		14.03		15.03		16.03		
Seewen	<i>an</i>				07.11		08.11		09.11		10.11		11.11		12.11		13.11		14.11		15.11		16.11		
Seewen	<i>ab</i>				07.15		08.15		09.15		10.15		11.15		12.15		13.15		14.15		15.15		16.15		
Bretzwil					07.20		08.20		09.20		10.20		11.20		12.20		13.20		14.20		15.20		16.20		
Nunningen	an				07.26		08.26		09.26		10.26		11.26		12.26		13.26		14.26		15.26		16.26		

←

Nunningen	ab		06.30		07.30		08.30		09.30		10.30		11.30		12.30		13.30		14.30		15.30		16.30		
Seewen	<i>an</i>		06.41		07.41		08.41		09.41		10.41		11.41		12.41		13.41		14.41		15.41		16.41		
Seewen	<i>ab</i>		06.45		07.45		08.45		09.45		10.45		11.45		12.45		13.45		14.45		15.45		16.45		
Büren	<i>an</i>		06.53		07.53		08.53		09.53		10.53		11.53		12.53		13.53		14.53		15.53		16.53		
Büren	<i>ab</i>	06.20	06.54		07.54		08.54		09.54		10.54		11.54		12.54		13.54		14.54		15.54		16.54		
Nuglar		06.32		07.32		08.32		09.32		10.32		11.32		12.32		13.32		14.32		15.32		16.32		17.32	
Liestal	an	06.43	07.05	07.43	08.05	08.43	09.05	09.43	10.05	10.43	11.05	11.43	12.05	12.43	13.05	13.43	14.05	14.43	15.05	15.43	16.05	16.43	17.05	17.43	
<i>S3 nach Basel</i>	<i>ab</i>		07.10		08.10		09.10		10.10		11.10		12.10		13.10		14.10		15.10		16.10		17.10		
<i>IR nach Basel</i>	<i>ab</i>	06.48		07.48		08.48		09.48		10.48		11.48		12.48		13.48		14.48		15.48		16.48		17.48	

→

				1	2																				
<i>IR von Basel</i>	<i>an</i>				17.08		18.08		19.08																
<i>S3 von Basel</i>	<i>an</i>	16.46		17.46		18.46		19.46	20.46	21.46	22.46	23.46													
Liestal	ab	16.51	17.14	17.51	18.14	18.51	19.14	19.51	20.51	21.51	22.51	23.51													
Nuglar			17.24	18.24	19.24	20.01	21.01	22.01	23.01	00.01															
Büren	<i>an</i>	17.02		18.02		19.02		20.14	21.14	22.14	23.14	00.14													
Büren	<i>ab</i>	17.03		18.03		19.03																			
Seewen	<i>an</i>	17.11		18.11		19.11																			
Seewen	<i>ab</i>	17.15		18.15		19.15																			
Bretzwil		17.20		18.20		19.20																			
Nunningen	an	17.26		18.26		19.26																			

←

Nunningen	ab	17.30		18.30																					
Seewen	<i>an</i>	17.41		18.41																					
Seewen	<i>ab</i>	17.45		18.45																					
Büren	<i>an</i>	17.53		18.53																					
Büren	<i>ab</i>	17.54		18.54				20.20	21.20	22.20	23.20														
Nuglar			18.32		19.32			20.32	21.32	22.32	23.32														
Liestal	an	18.05	18.43	19.05	19.43			20.43	21.43	22.43	23.43														
<i>S3 nach Basel</i>	<i>ab</i>	18.10		19.10																					
<i>IR nach Basel</i>	<i>ab</i>		18.48		19.48			20.48	21.48	22.48	23.48														

Anhang 13: Fahrplanentwürfe

Linien 73/74 Liestal - Büren - Seewen - Nunningen

Stand: 9.2.2012

Sonntag

→

			2	1																			
<i>IR von Basel</i>	<i>an</i>						08.08		09.08		10.08		11.08		12.08		13.08		14.08		15.08	16.08	
<i>S3 von Basel</i>	<i>an</i>					07.46		08.46		09.46		10.46		11.46		12.46		13.46		14.46		15.46	16.08
Liestal	ab					07.51	08.14	08.51	09.14	09.51	10.14	10.51	11.14	11.51	12.14	12.51	13.14	13.51	14.14	14.51	15.14	15.51	16.14
Nuglar							08.24		09.24		10.24		11.24		12.24		13.24		14.24		15.24		16.24
Büren	<i>an</i>					08.02		09.02		10.02		11.02		12.02		13.02		14.02		15.02		16.02	
Büren	<i>ab</i>					08.03		09.03		10.03		11.03		12.03		13.03		14.03		15.03		16.03	
Seewen	<i>an</i>					08.11		09.11		10.11		11.11		12.11		13.11		14.11		15.11		16.11	
Seewen	<i>ab</i>					08.15		09.15		10.15		11.15		12.15		13.15		14.15		15.15		16.15	
Bretzwil						08.20		09.20		10.20		11.20		12.20		13.20		14.20		15.20		16.20	
Nunningen	an					08.26		09.26		10.26		11.26		12.26		13.26		14.26		15.26		16.26	

←

Nunningen	ab					07.30		08.30		09.30		10.30		11.30		12.30		13.30		14.30		15.30		16.30		
Seewen	<i>an</i>					07.41		08.41		09.41		10.41		11.41		12.41		13.41		14.41		15.41		16.41		
Seewen	<i>ab</i>					07.45		08.45		09.45		10.45		11.45		12.45		13.45		14.45		15.45		16.45		
Büren	<i>an</i>					07.53		08.53		09.53		10.53		11.53		12.53		13.53		14.53		15.53		16.53		
Büren	<i>ab</i>					07.20	07.54	08.54		09.54		10.54		11.54		12.54		13.54		14.54		15.54		16.54		
Nuglar						07.32	08.32	09.32		10.32		11.32		12.32		13.32		14.32		15.32		16.32		17.32		
Liestal	an					07.43	08.05	08.43	09.05	09.43	10.05	10.43	11.05	11.43	12.05	12.43	13.05	13.43	14.05	14.43	15.05	15.43	16.05	16.43	17.05	17.43
<i>S3 nach Basel</i>	<i>ab</i>					08.10		09.10		10.10		11.10		12.10		13.10		14.10		15.10		16.10		17.10	17.48	
<i>IR nach Basel</i>	<i>ab</i>					07.48		08.48		09.48		10.48		11.48		12.48		13.48		14.48		15.48		16.48	17.48	

→

							1						2												
<i>IR von Basel</i>	<i>an</i>		17.08		18.08		19.08																		
<i>S3 von Basel</i>	<i>an</i>	16.46	17.08	17.46	18.46	19.46	20.46	21.46	22.46	23.46															
Liestal	ab	16.51	17.14	17.51	18.14	18.51	19.14	19.51	20.51	21.51	22.51	23.51													
Nuglar			17.24		18.24		19.24		20.01	21.01	22.01	23.01	00.01												
Büren	<i>an</i>	17.02		18.02		19.02		20.14	21.14	22.14	23.14	00.14													
Büren	<i>ab</i>	17.03		18.03		19.03																			
Seewen	<i>an</i>	17.11		18.11		19.11																			
Seewen	<i>ab</i>	17.15		18.15		19.15																			
Bretzwil		17.20		18.20		19.20																			
Nunningen	an	17.26		18.26		19.26																			

←

Nunningen	ab	17.30		18.30																				
Seewen	<i>an</i>	17.41		18.41																				
Seewen	<i>ab</i>	17.45		18.45																				
Büren	<i>an</i>	17.53		18.53																				
Büren	<i>ab</i>	17.54		18.54				20.20	21.20	22.20	23.20													
Nuglar			18.32		19.32			20.32	21.32	22.32	23.32													
Liestal	an	18.05	18.43	19.05	19.43			20.43	21.43	22.43	23.43													
<i>S3 nach Basel</i>	<i>ab</i>	18.10		19.10																				
<i>IR nach Basel</i>	<i>ab</i>		18.48		19.48			20.48	21.48	22.48	23.48													

Anhang 14: Fahrplanentwürfe

Linie 116 Grellingen - Seewen - Nunningen

Stand: 9.2.2012

Montag - Freitag

→

<i>S3 von Basel</i>		<i>an</i>			06.22	06.52	07.22	08.22	09.22	10.22	11.22	12.22	13.22	14.22	15.22	16.22	17.22	18.22	19.22	20.22
Grellingen	ab				06.28	06.58	07.28	08.28	09.28	10.28	11.28	12.28	13.28	14.28	15.28	16.28	17.28	18.28	19.28	20.28
Seewen	ab				06.36	07.06	07.36	08.36	09.36	10.36	11.36	12.36	13.36	14.36	15.36	16.36	17.36	18.36	19.36	20.36
Bretzwil	ab				06.41		07.41	08.41	09.41	10.41	11.41	12.41	13.41	14.41	15.41	16.41	17.41	18.41	19.41	20.41
Nunningen	an				06.47		07.47	08.47	09.47	10.47	11.47	12.47	13.47	14.47	15.47	16.47	17.47	18.47	19.47	20.47

←

Nunningen	ab		06.07		07.07		08.07	09.07	10.07	11.07	12.07	13.07	14.07	15.07	16.07	17.07	18.07	19.07	20.07	
Bretzwil	ab		06.11		07.11		08.11	09.11	10.11	11.11	12.11	13.11	14.11	15.11	16.11	17.11	18.11	19.11	20.11	
Seewen	ab		06.18	06.48	07.18		08.18	09.18	10.18	11.18	12.18	13.18	14.18	15.18	16.18	17.18	18.18	19.18	20.18	
Grellingen	an		06.27	06.57	07.27		08.27	09.27	10.27	11.27	12.27	13.27	14.27	15.27	16.27	17.27	18.27	19.27	20.27	
<i>S3 nach Basel</i>		<i>ab</i>	06.32	07.04	07.32		08.32	09.32	10.32	11.32	12.32	13.32	14.32	15.32	16.32	17.32	18.32	19.32	20.32	

■ Zusatzkurse (mit Fahrzeug der Linie 67)

Anhang 14: Fahrplanentwürfe

Linie 116 Grellingen - Seewen - Nunningen

Stand: 9.2.2012

Samstag



<i>S3 von Basel</i>	<i>an</i>																
Grellingen	ab		07.22	08.22	09.22	10.22	11.22	12.22	13.22	14.22	15.22	16.22	17.22	18.22	19.22	20.22	
Seewen	ab		07.28	08.28	09.28	10.28	11.28	12.28	13.28	14.28	15.28	16.28	17.28	18.28	19.28	20.28	
Bretzwil	ab		07.36	08.36	09.36	10.36	11.36	12.36	13.36	14.36	15.36	16.36	17.36	18.36	19.36	20.36	
Nunningen	an		07.41	08.41	09.41	10.41	11.41	12.41	13.41	14.41	15.41	16.41	17.41	18.41	19.41	20.41	
			07.47	08.47	09.47	10.47	11.47	12.47	13.47	14.47	15.47	16.47	17.47	18.47	19.47	20.47	



Nunningen	ab		07.07	08.07	09.07	10.07	11.07	12.07	13.07	14.07	15.07	16.07	17.07	18.07	19.07	20.07	
Bretzwil	ab		07.11	08.11	09.11	10.11	11.11	12.11	13.11	14.11	15.11	16.11	17.11	18.11	19.11	20.11	
Seewen	ab		07.18	08.18	09.18	10.18	11.18	12.18	13.18	14.18	15.18	16.18	17.18	18.18	19.18	20.18	
Grellingen	an		07.27	08.27	09.27	10.27	11.27	12.27	13.27	14.27	15.27	16.27	17.27	18.27	19.27	20.27	
<i>S3 nach Basel</i>	<i>ab</i>		07.32	08.32	09.32	10.32	11.32	12.32	13.32	14.32	15.32	16.32	17.32	18.32	19.32	20.32	

Anhang 14: Fahrplanentwürfe

Linie 116 Grellingen - Seewen - Nunningen

Stand: 9.2.2012

Sonntag



<i>S3 von Basel</i>	<i>an</i>																
Grellingen	ab		08.22	09.22	10.22	11.22	12.22	13.22	14.22	15.22	16.22	17.22	18.22	19.22	20.22		
Seewen	ab		08.28	09.28	10.28	11.28	12.28	13.28	14.28	15.28	16.28	17.28	18.28	19.28	20.28		
Bretzwil	ab		08.36	09.36	10.36	11.36	12.36	13.36	14.36	15.36	16.36	17.36	18.36	19.36	20.36		
Nunningen	an		08.41	09.41	10.41	11.41	12.41	13.41	14.41	15.41	16.41	17.41	18.41	19.41	20.41		
			08.47	09.47	10.47	11.47	12.47	13.47	14.47	15.47	16.47	17.47	18.47	19.47	20.47		



Nunningen	ab		08.07	09.07	10.07	11.07	12.07	13.07	14.07	15.07	16.07	17.07	18.07	19.07	20.07		
Bretzwil	ab		08.11	09.11	10.11	11.11	12.11	13.11	14.11	15.11	16.11	17.11	18.11	19.11	20.11		
Seewen	ab		08.18	09.18	10.18	11.18	12.18	13.18	14.18	15.18	16.18	17.18	18.18	19.18	20.18		
Grellingen	an		08.27	09.27	10.27	11.27	12.27	13.27	14.27	15.27	16.27	17.27	18.27	19.27	20.27		
<i>S3 nach Basel</i>	<i>ab</i>		08.32	09.32	10.32	11.32	12.32	13.32	14.32	15.32	16.32	17.32	18.32	19.32	20.32		